

Made-to-Print Services

Cost-effective, top-quality custom parts and assemblies

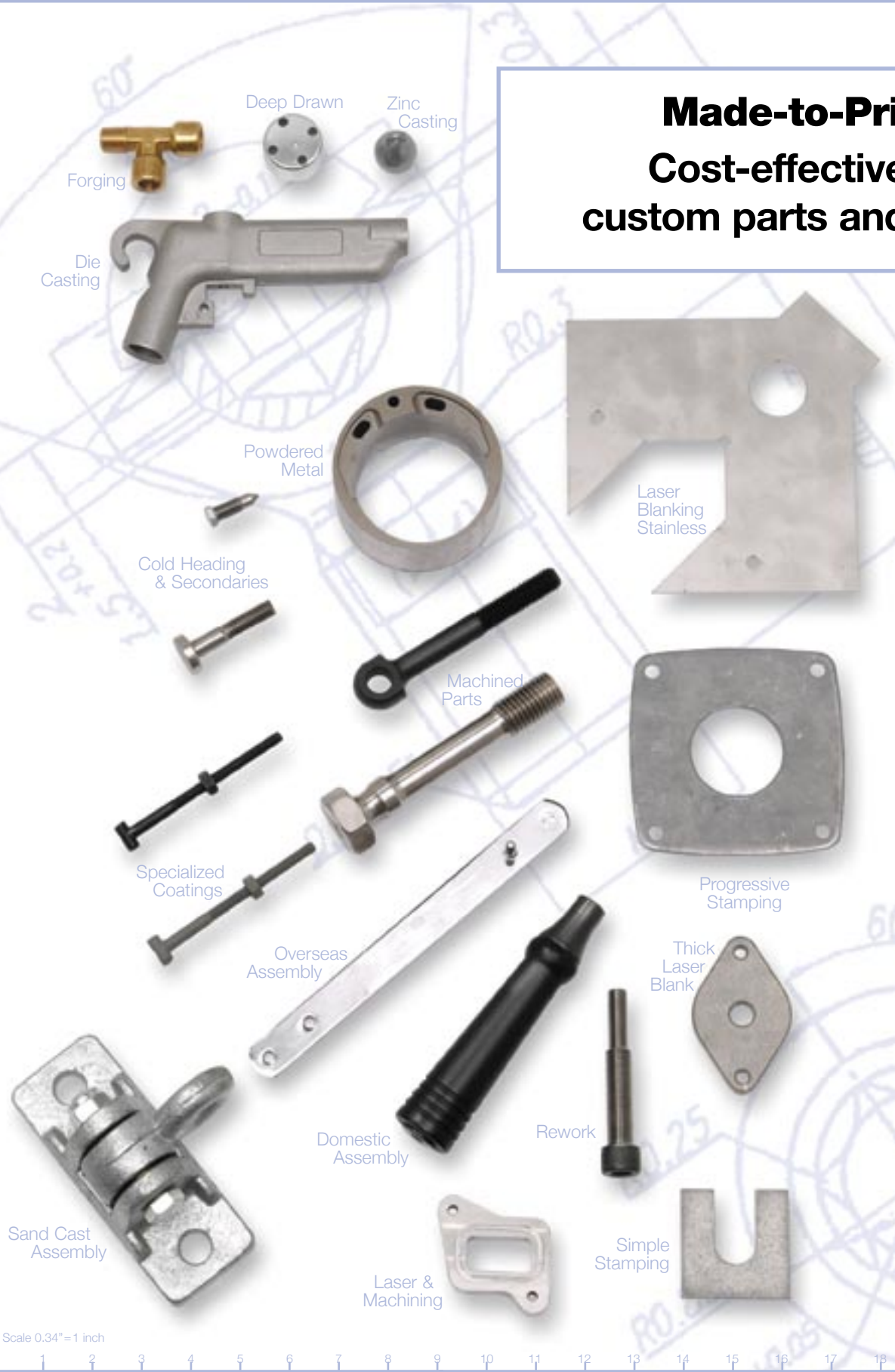

- ▶ Turn to our experienced engineering team
- ▶ Take advantage of top-notch trouble shooting, often the same day you call
- ▶ Get the highest quality parts at the best prices through our established supplier network
- ▶ Release and pay only for what you need, but buy in large quantities for better pricing
- ▶ Or operate a leaner supply change with vendor managed inventory

See inside for more...



**ATLANTIC®
FASTENERS**
ISO 9001 Registered

1-800-800-BOLT (2658)

End your sourcing headaches: top suppliers and \$100 Service Guarantees

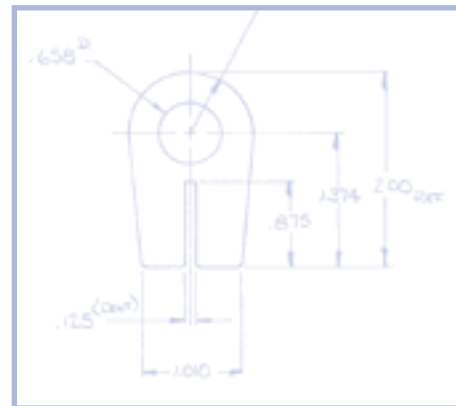

➤ **N**ow, get custom small parts or fasteners that take the least amount of time, effort and tooling to install and require the least amount of rework afterwards. Atlantic's Made-to-Print Services specializes in lowering your "in-place" costs. Add to that our inventory management offerings and you get a total lower cost solution to your small custom part requirements.

Call us for:

- Direct overseas sourcing, upon request
- Application engineering and problem solving
- Multi-part assembly
- New product design support
- Laboratory inspection and failure analysis
- Long-term retention of chemical/physical lot traceability reports
- Assembly process review and reengineering
- Value engineering
- Drawings prepared to your specifications

We work with the most reliable, ISO qualified domestic and offshore suppliers, so count on fast quoting, error-free shipments, accurate billing, and on-time deliveries. In fact, if our suppliers don't deliver on these promises, we issue you a \$100 credit! Who else in the industry offers that? For more on our six \$100 Service Guarantees, visit atlanticfasteners.com.

Through our highly dependable sources we deliver:

- Castings
- Cold headed components
- Specialized plating, coatings and metallurgical processes
- Military/aerospace requirements
- Laser and waterjet cutting
- Cryogenic wear treatment
- Stampings (short and long runs)
- Plastic and rubber molded parts

- Screw machining
- Prototypes
- Exotic materials
- Hot heading
- Powdered metal parts
- Deep drawn parts
- Custom springs and wire forms



Using our Skidmore-Wilhelm tester, mechanical engineer Don Mahall will help you determine the amount of torque required to achieve a specified bolt tension.

Save money! Order in large quantities, receive and pay as you go

You don't pay an excessive fee when we warehouse your large custom orders. With our "blanket order" program, purchase up to a year's supply for the best price and we store your inventory and send you quantities as needed. You only pay for shipments as they're released.



Let our expert engineers and draftspersons suggest the best manufacturing alternatives for you.

Or have us maintain your supplies onsite, and satisfy the whole company

With our vendor managed inventory program, you all but eliminate errors since your people no longer hand write orders or phone descriptions. Your purchasing department isn't stuck ordering specials. Manufacturing appreciates the reduced inventories — checked, maintained, and restocked at point-of-use by us — and the elimination of stock-outs. And accounting beams as it pays just one monthly bill, if requested.

Here's how it works:

- You determine the supply levels you want maintained
- We bar code label all stocking locations (point-of-use at your assembly stations saves you most)
- We visit according to your schedule to maintain the stock levels by bar code scanning
- We download your orders directly into our computer
- We ship your packages, clearly labeled by point-of-use destination, so your receiving department can quickly forward them. Or, if you prefer, we restock your shelves for you
- We send one monthly bill, if you want
- We provide usage, fill rate and other management reports by stocking location

Get quick response, often the same day. So come to us for your special parts and assemblies

Perhaps you're unfamiliar with a part or process or your in-house engineering department is overwhelmed with other tasks. Yet, you can't afford to wait weeks for co-workers to familiarize themselves or free up time to help. Contact us today. We pride ourselves on quick response.

- 1** Phone Dan McKeeman, manager of Atlantic's Made-to-Print Services, at **1-800-800-BOLT (2658) ext. 410** with a description of your needs
- 2** Fax your print or specifications to **1-413-785-5770**
- 3** E-mail the same to **dan@atlanticfasteners.com**

At your request, Dan and his technical team can visit your company to discuss your custom part, assembly or inventory management needs.



Need a print for a part? Draftsperson Dana Lees will create a CAD drawing for you.

Phone for expert help

With 28 years experience in manufacturing problem solving, Dan McKeeman heads up the Made-to-Print Services team. His specialties include application engineering, small part/fastener design support, automated assembly systems, and in-place cost reduction.

When he's not helping customers with innovative small parts solutions, Dan's building a high-wing, 4-seat short take-off and landing experimental airplane from a kit. He's forming flat sheet metal into the airplane parts as he goes and fastening it all together with Textron Avex® blind rivets.

Dan's Made-to-Print team includes Don Mahall, a degreed mechanical engineer with a 35-year background in design, fabrication, assembly and new product development and Dana Lees, a quality inspector and CAD professional with 16 years of hands-on experience.

Let us solve your custom part problems — starting today!

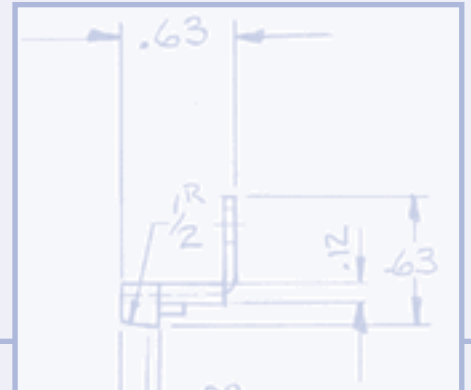

A single engine pilot since 1969, Dan will spend five years and over \$50,000 to complete his Zenith Aircraft kit plane, made primarily from 6061-T6 aluminum.



Shown here with a rudder from his four-seater, Dan estimates he will have installed nearly 10,000 Textron Avex® rivets when complete. Luckily, he has access to an AvdelCherry® hydra-pneumatic power riveter!



Rebuilding a 22-year-old, 180 HP Lycoming engine with only 245 hours of use took Dan an entire winter. It came intact from a plane wrecked by a tornado at Bradley International Airport.

MADE-TO-PRINT SUCCESS STORIES

SUCCESS STORY #1

Made-to-Print helps performance auto parts maker cut repair time by 90% — saving hundreds of dollars in the process.

The challenge

A highly respected supplier of high-end automotive equipment was spending an average of 20 minutes removing socket cap screws with a locking thread patch when overhauling aluminum oil pumps. Repairers applied heat to soften the nylon thread patch and speed up the process, but when the screws came out the soft internal aluminum threads were damaged.

Made-to-Print's analysis

The senior manufacturing manager turned to Made-to-Print for a solution. Our diagnosis: the locking thread patch, which was supposed to keep the screw from backing out, was too hard and generated too much pressure on entry. As a result, the prevailing torque smeared and galled the soft internal aluminum thread.

The solution

Pre-applied Loctite. It stays soft and flexible during assembly — causing no damage to the internal threads — then typically locks within 48 hours. After testing, the manufacturer chose a medium duty grade for easier removal in the event of future overhauls.

Fastener removal now takes just 2 minutes — a 90% improvement in repair time!

SUCCESS STORY #2

Stove maker needs custom assembly — *Fast*. Made-to-Print comes through in just six weeks from print to fully assembled product.

The dilemma

Due to sudden demand, the North American manufacturing division of a European company was in immediate need of stove handles — and only exceptionally well-crafted handles would do for the high-end cast iron stoves it produces.

Made-to-Print to the rescue

Although the handles weren't a new part, the company's usual source couldn't ship them quickly enough. Fortunately, a project engineer knew about Atlantic's Made-to-Print service and called us. Using his existing specifications, we tapped our supplier network to put together a top-quality assembly under extremely tight time constraints. The wood stove handles consist of four parts — threaded rod, an internally threaded handle receiver, a nut housing for the butt end and a turned and painted hardwood handle.

The result

When it all came together, the manufacturer received the first shipment after only 6 weeks. The project engineer was thrilled. He noted, "We needed and got a product of exceptional quality — anyone using a wood stove gets his or her first and most lasting impression from the look and feel of the handles. All in all, it was a worthwhile experience."

Shouldn't your success story be featured here?

Why leading companies trust Made-to-Print . . . and why you should, too

► **Expect the right part, every time.**

Upon request, your custom parts orders undergo a rigorous AQL (acceptable quality level) inspection in our fully equipped lab. Our testing equipment is specifically designed for small parts and fasteners. And it's connected to the latest Starrett inspection software, a fast, precise system that offers automatic documentation for necessary record keeping.

► **Rely on our commitment to error-free prints and revisions.** Since we're ISO registered, we internally audit all elements of our quality system — including document control — every year. Twice a year a third party examiner also audits portions of our system.

► **Count on continued improvement in our products and services.** Atlantic always looks for ways to improve and serve you better. Beyond ISO, our current quality initiatives include kaizens and a cross-training program to help eliminate waste, streamline processes and run leaner.

Phone us today to learn how you can save on custom fasteners and small parts.

Other ways Made-to-Print can save you money

► **Streamline manufacturing and reduce labor costs** — outsource the kitting and light assembly of made-to-print parts to us. Our services include specialized packaging, custom labeling with graphics and even 100% inspection.

► **Free up cash** — our consignment service lets you keep Atlantic-owned inventory in your plant while paying for parts only as you use them.

► **Ask for FREE receiving and restocking** — when Atlantic manages your inventory by bar code scanning, we can also put away items and forward necessary paperwork.

► **Minimize accounting paperwork; end reconciling headaches** — our monthly invoicing option includes summaries and itemized backup.

► **Cut fewer checks** — Atlantic accepts Visa, MasterCard, and American Express.

Call now for more information on how to save time and cut costs.



**ATLANTIC®
FASTENERS**

ISO 9001 Registered
49 Heywood Ave.
W. Springfield, MA 01089

atlanticfasteners.com
1-413-785-5770 Fax
1-800-800-BOLT (2658)